

EMC Interface Connection Panel Site B **QMF17a Issue 05**

The following information is to enable your equipment to be connected to our test chambers. Please provide any leads from your product, with connectors that will interface with the panel below:

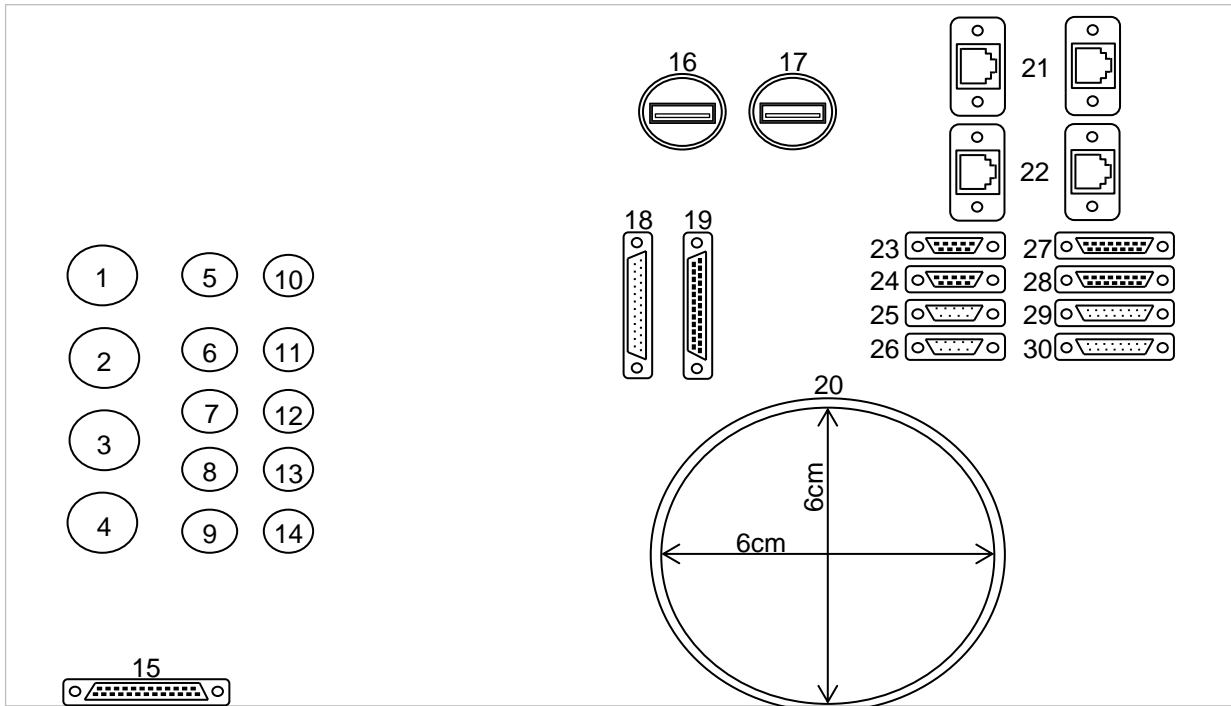

Number	Type	Inside Chamber	Outside Chamber
1	N Type	Female	Female
2	N Type	Female	Female
3	N Type	Female	Female
4	N Type	Female	Female
5	BNC	Female	Female
6	BNC	Female	Female
7	BNC	Female	Female
8	BNC	Female	Female
9	BNC	Female	Female
10	BNC	Female	Female
11	BNC	Female	Female
12	BNC	Female	Female
13	BNC	Female	Female
14	BNC	Female	Female
15	25 Way D Type	KEC Brentwood use only	
16	USB	Type A	Type B
17	USB	Type A	Type B
18	25 Way D Type	Male	Female
19	25 Way D Type	Female	Male
20	Wave guide aperture	Dimensions: 600mm Diameter	
21	2x CAT 5E	RJ45 Jack	RJ45 Jack
22	2x CAT 5E	RJ45 Jack	RJ45 Jack
23	9 Way D Type	Female	Male
24	9 Way D Type	Female	Male
25	9 Way D Type	Male	Female
26	9 Way D Type	Male	Female
27	15 Way D Type	Female	Male
28	15 Way D Type	Female	Male
29	15 Way D Type	Male	Female
30	15 Way D Type	Male	Female

Waveguide
All leads passed through the waveguide may be ferrite clamped to prevent RF from entering the screened chamber.

Connector Terminals
All "D" connectors are filtered so as not to take any form of RF into the screened chamber.

Signal Leads
All signal leads must be 3m (or greater) in length from your equipment to the Interface Panel, and 3.5m (or greater) from Interface Panel to the support equipment outside the chamber.